

THE RED LINE

WNS2220 & WS2220 HEPA UPGRADE

**PURIFY AIR WHILE KEEPING WORKERS
SAFE FROM HARMFUL DUST!**

BEFORE HEPA

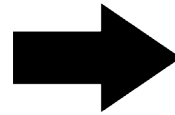
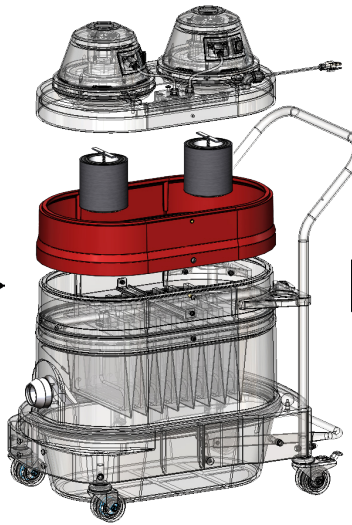
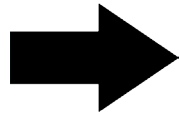
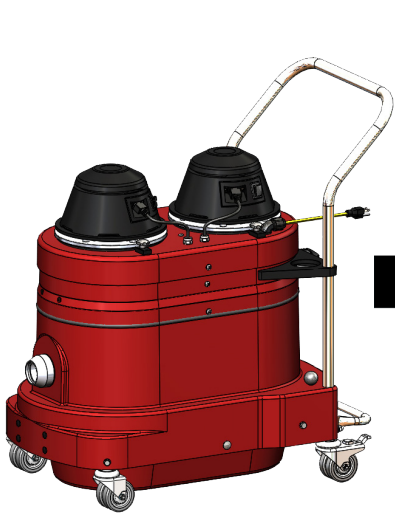

AFTER HEPA

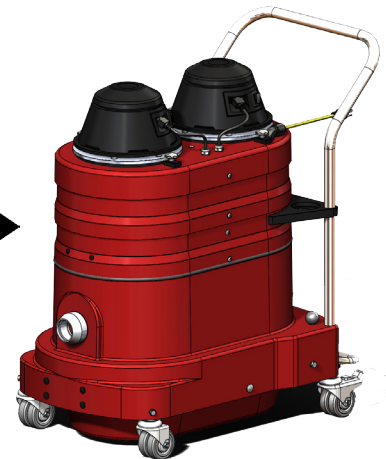

COMPLIANT TO OSHA'S SILICA DUST STANDARDS

If your material requires an additional level of filtration to ensure workers are kept safe from dangerous contaminants like silica dust, the HEPA upgrade is your absolute solution. These HEPA filters are compliant to OSHA's silica dust standards, and are easy to install onto your WNS2220 or WS2220 vacuum system. Best of all, they serve to full-proof the vacuum's existing primary MicroClean filtration system. MicroClean filters are industry-leading and already compliant to OSHA's silica standards for dust collectors. At 99.9% efficient @ 0.5 microns, they allow very few particles to get past their initial filtration process. An additional HEPA filter will ensure ultimate filtration that complies with all of OSHA's silica dust standards.

#35192CON Features

- 99.97% @ 0.3 microns
- Modular construction makes them easy to install and upgrade
- Finite filtering purifies air
- Compliant to OSHA's silica dust collection standards

